



ADVANCE COOL TECHNOLOGY CO.,LTD.
THE CHILLER EXPERT

High & Large Space Air Conditioner



 *Low Noise*

 *Energy Saving*

 *Light Breeze Air Supply*

 *Wireless intelligent control*

The energy-saving air conditioning system for high and large spaces encompasses various media types



ADVANCE COOL TECHNOLOGY CO.,LTD.

www.advance-cool.com

We are specialized in Manufacturing Water Chiller Unit and Package Chiller range from Small Chiller to Large Chiller Plant using both Scroll compressor & Screw compressor as well as install Complete Cooling System including Machine Cooling System, Large Air Conditioning System

Our Air Cooled Chiller and Water Cooled Chiller are equipped with all high quality and well known components such as Copeland Compressor. With our experiences of more than 40 years we are capable of serving our customers' needs by providing High Quality Chillers as well as Outstanding Services.

Our service teams are highly experienced and well trained, we can ensure quality and fast service within 24hours. We do accept custom made chillers according to customer specific requirement.

Office

300/3 Soi Ladprao 107 Klongchan Bangkok, 10240 Bangkok Thailand Website:www.advance-cool.com
Tel : 02-187-0660,02-187-0661,02-187-0663 Fax : 02-187-0662 Email : inquiry@advance-cool.com

Factory

155 Moo 4, Suwan Sot Road, Wang Krachan, Muang Nakhon Nayok, Nakhon Nayok 26000

Directory

Indoor Fan Coil Unit

System Introduction	2
Working Principle	4
Technical Specifications	5
Product Parameters	6
Technical Characteristics	8

Outdoor Unit

Working Principle	13
Functions	13
Specification	14

HVLS FANS

Working Principle	16
Design Suggestions	18
Technical Specifications	19
Standard Control	20
Optional IoT Control	21
Optional Wireless Control System	22
Advantages	23
PMSM VS Gear Shifting Motor	23
ACT-F Inner VS Outer Rotor	24
Installation	25

Control System

Working Principle	27
Functions	28
Specification	28
Application	29



CASES

Common occasions

ACT primarily offers energy-efficient air conditioner systems for high and large space, including heating units, heating and cooling units, gas heating units, VRF air conditioners, HVLS fans, industrial controls and related products which allow to meet the needs of heating, cooling, ventilation, humidification, dehumidification and auto control for buildings ranging from 4 to 30m in height.



Indoor Fan Coil Unit



Indoor Unit ACT-K-I / ACT-K-II

Applications: ideal for high and large space that needs cooling and heating.

Use chilled water or R410A as the medium.

Model: ACT-K-I, ACT-K-II

Function: cooling, heating

Cold and hot source: Chilled water or R410A

Control mode: wireless control, variable frequency, auto monitoring



System Introduction



ACT products for high & large space are innovative air conditioners, which are successfully developed for the special environment of large space. The products have been widely used in industrial plant, warehouse and automotive maintenance center, logistics center, large gymnasium, exhibition hall, car shop, supermarket, department store and other large spaces.

We have used the combination of HVAC, fluid mechanics, software, wireless communication, frequency conversion and automatic control to achieve the purpose, and adopting the Internet, 4G, 5G communication technology to achieve the remote monitoring of users. This plan adopts efficient air distribution to reasonably distribute air flow and achieve energy saving and comfortable effect. The system has met the requirements of large space heating, cooling, ventilation, humidification, dehumidification, heat energy recovery, etc. It is suitable for 4-30m high construction sites, which is characterized by mature technology, simple implementation, flexible control, high efficiency and energy saving.

Working Principle

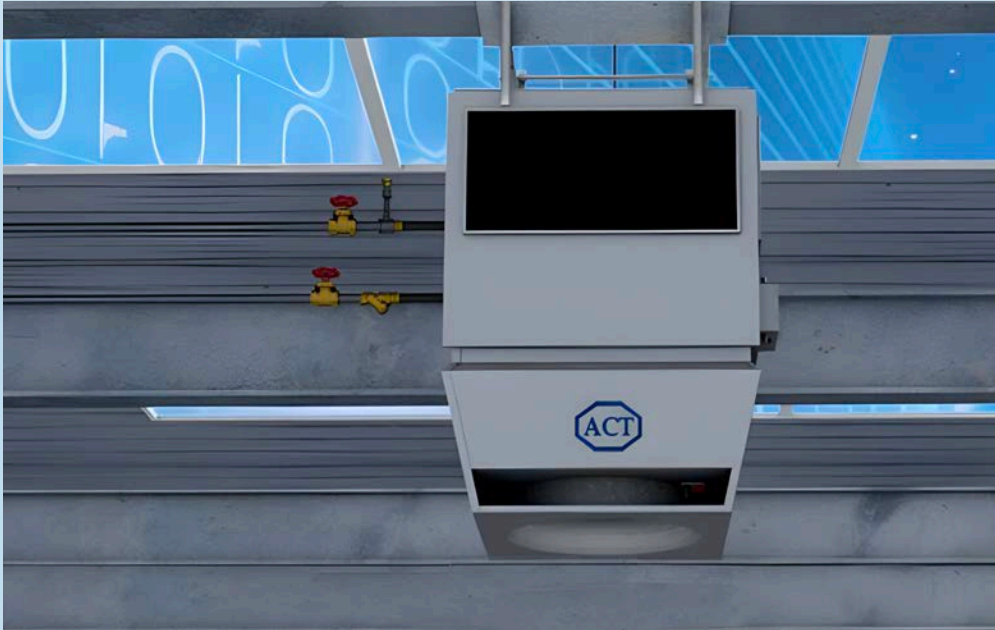

- ◆ When hot/cold water or steam passes the equipment, the efficient heat exchanger in the equipment is used to achieve rapid heating/cooling of the air.

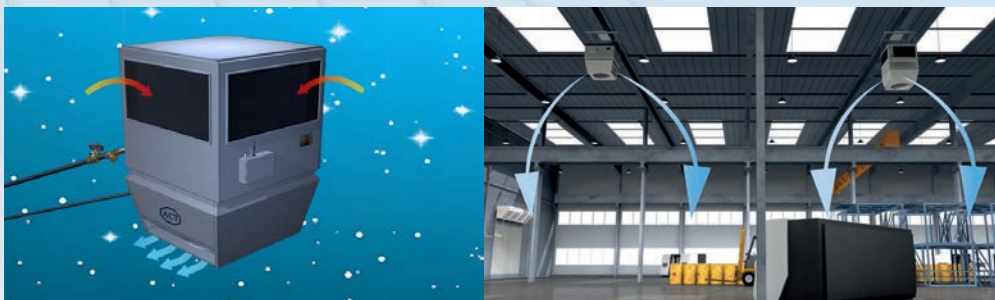

- ◆ The large wind pressure axial flow fan installed on the top is used to forcedly press the hot/cold air down. Then the air is subject to pressure boost twice through the silencer sponge and the lower trapezoidal convergence, swirls out from the nozzle through the guide vane and is distributed throughout the space from top to down.



Technical Specifications

ACT-K



Recirculated Air Heating and Cooling Units

Model		ACT-K-I	ACT-K-II
Fan speed	r/min	0~900	0~860
Standard circulating air volume	m ³ /h	0~6900	0~10100
Voltage	V	380±5%	380±5%
Electric power	kW	0~0.85	0~1.80
Current	A	0~1.65	0~3.60
Applicable installation height	m	4~15	4~23
Control mode		Infinite regulation of variable air volume	
Noise	dB	<60	<60

* If the installation height is outside the scope of application, please communicate with the manufacturer and customize the non-standard model.

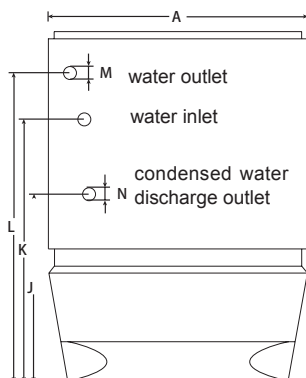
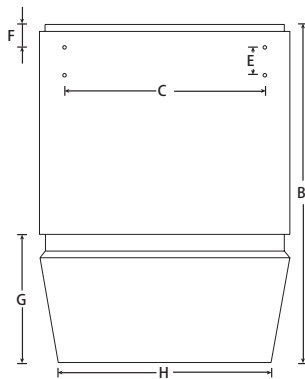

Unit size

Model		ACT-K-I	ACT-K-II
A	mm	900	1100
B	mm	1250	1442
C	mm	735	920
E	mm	100	100
F	mm	95	95
G	mm	480	568
H	mm	765	935
J	mm	660	789
K	mm	890	1032
L	mm	1050	1292
M (internal thread)	mm	DN40	DN50
N (external thread)	mm	DN25	DN32
Weight	kg	160	235
Water volume	L	10.0	13.2

※For more materials and parameters of non-standard models, such as anti-explosion, anti-corrosion, purification and other functional units, please consult our representative

 **Product Parameters**

Return air temperature		10°C				15°C				20°C			
Heating medium temperature	Model	Q KW	TS °C	m _w L/h	Δpw kpa	Q KW	TS °C	m _w L/h	Δpw kpa	Q KW	TS °C	m _w L/h	Δpw kpa
90/70	ACT-K-I	88	59	3935	10	-	-	-	-	-	-	-	-
80/60	ACT-K-I	76	52	3399	8	68	54	3041	7	61	55	2728	5
70/50	ACT-K-I	62	44	2773	5	55	46	2460	4	48	48	2147	4
60/50	ACT-K-I	53	37	4558	7	49	37	4214	5	41	41	3526	5
60/40	ACT-K-I	47	36	2102	3	39	37	1744	2	30	37	1342	2
80/70	ACT-K-I	85	57	7602	30	78	59	6976	25	70	60	6261	22
45/40	ACT-K-I	39	30	6976	25	29	32	5188	16	20	35	3578	9
90/70	ACT-K-II	144	59	6440	10	138	60	5934	8	125	60	5489	5
80/60	ACT-K-II	140	56	5977	8	128	57	5504	5	116	58	4988	5
70/50	ACT-K-II	134	41	5762	5	119	43	5117	4	105	45	4515	4
60/50	ACT-K-II	110	37	9460	8	94	39	8080	4	83	41	7138	5
60/40	ACT-K-II	106	35	4558	4	92	37	3956	2	75	39	3225	2
80/70	ACT-K-II	148	58	12728	26	140	59	12040	24	127	60	10922	20
45/40	ACT-K-II	79	31	13588	30	68	33	11696	21	59	35	10148	20

"-" indicates that the air supply temperature has exceeded the maximum allowable supply air temperature 60°C, so this operation status is strictly prohibited.

Marking instruction: Q = Thermal output power
 t_s = Supply air temperature
 m_w = Water volume flow rate
 Δpw = Water pressure loss

Maximum operating pressure: 800kpa
 Highest supply air temperature: 60°C
 Highest background temperature: 40°C



Product Parameters

Cooling medium temperature			7/12°C					8/14°C					10/16°C				
t _{ai} °C	rh %	Model	Q KW	T _s °C	m _c kg/h	m _w L/h	Δpw kpa	Q KW	T _s °C	m _c kg/h	m _w L/h	Δpw kpa	Q KW	T _s °C	m _c kg/h	m _w L/h	Δpw kpa
24	30	ACT-K-I	14	16	0.2	2432	5	12	17	0.2	1720	4	10	19	0.7	1433	2
	50	ACT-K-I	14	16	0.5	2432	5	12	17	0.2	1720	4	10	19	0.6	1433	2
	70	ACT-K-I	27	16	18.9	4690	18	20	18	11.2	2866	8	12	19	3.5	1720	4
26	30	ACT-K-I	17	17	0.4	2953	9	15	18	0.2	2150	5	12	19	0.2	1720	4
	50	ACT-K-I	20	17	4.9	3474	12	15	17	0.2	2150	5	12	19	0.2	1720	4
	70	ACT-K-I	38	16	29	6601	33	31	18	22.4	4442	16	22	19	13.4	3153	9
28	30	ACT-K-I	20	17	0.2	3474	12	17	18	0.2	2436	5	15	20	0.2	2150	5
	50	ACT-K-I	29	17	14.2	5038	23	21	18	6.3	3009	9	15	20	0.2	2150	5
	70	ACT-K-I	47	16	39.9	8165	44	41	18	33.1	5875	27	34	19	26.3	4872	20
24	30	ACT-K-II	35	15	0.7	6080	13	29	16	0.3	4156	7	25	18	0.9	3583	5
	50	ACT-K-II	38	15	6.8	6601	15	29	16	0.6	4156	7	25	18	0.3	3583	5
	70	ACT-K-II	72	13	51.5	12508	46	54	15	36.8	7738	21	36	18	18.5	5159	10
26	30	ACT-K-II	41	16	0.6	7123	18	36	16	0.7	5159	10	30	18	0.3	4299	7
	50	ACT-K-II	57	15	23.6	9902	33	39	17	6.8	5589	11	30	18	0.3	4299	7
	70	ACT-K-II	89	14	68.3	15461	70	76	15	58.2	10891	36	62	17	44	8885	26
28	30	ACT-K-II	46	16	0.6	7991	22	41	16	1	5875	12	36	18	0.5	5159	10
	50	ACT-K-II	74	15	40.6	12855	46	60	16	27.6	8598	25	40	19	8.9	5732	12
	70	ACT-K-II	104	14	86.6	18067	84	93	15	75.7	13327	56	81	17	63.3	11607	39

Marking instruction:

t_{ai} = Inlet air temperature

Δpw = Water pressure loss

m_w = Water volume flow rate

Q = Cooling capacity

rh = Inlet air humidity

m_c = Condensed water production

t_s = Supply air temperature

Technical Characteristics

The large space dedicated air conditioner, lifted on the roof or stand column, achieves air heating through the heat exchangers in the equipment and then evenly distributes the cold and hot air throughout the space by means of efficient air distribution device to balance the indoor temperature and to eliminate the undesirable indoor temperature layers.

Stepless adjustment of wind speed and wind out air discharge angle while guaranteeing the temperature in the working area can achieve calm sense in the workspace environment and truly meet the comfortable needs in large space.



Three air supply modes

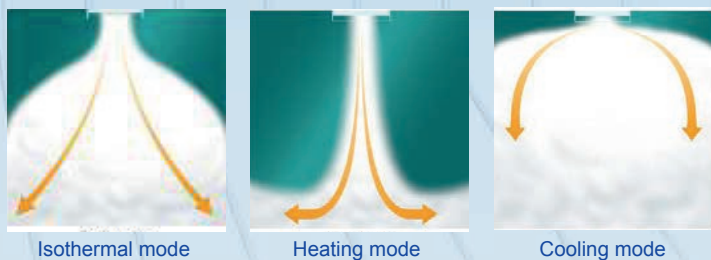

Schematic diagram of hot air circulating down



The condensed water in the cooling conditions is the core technical problem bothering the air conditioning technicians. ACT-K products conduct technical processing in the following two aspects, completely solving the leak of condensed water.

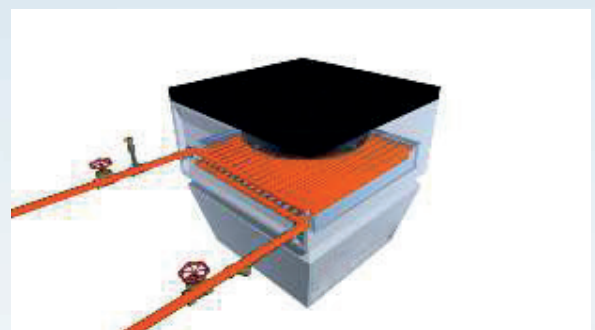

When hot water or steam passes the equipment, the efficient heat exchanger in the equipment is used to achieve rapid heating of the air.



Technical Characteristics

Condensed Water Treatment

The condensed water in the cooling conditions is the core technical problem bothering the air conditioning technicians. ACT-K products conduct technical processing in the following two aspects, completely solving the leak of condensed water.

Normal Operation Status of Fan

When there is cold water through the equipment surface air cooler in the normal operation conditions of the fan, the aluminum foil fin is attached with condensed water. The aluminum foil fin of the surface air cooler of the ACT-K products is parallel to the direction of air outlet. The wind area of the surface air cooler is accurately calculated to ensure that the wind speed through the fin cannot over the gravity of the condensed water under the maximum wind speed and that the condensed water automatically falls to the water catcher below the surface air cooler and is discharged through the condensed pipe.

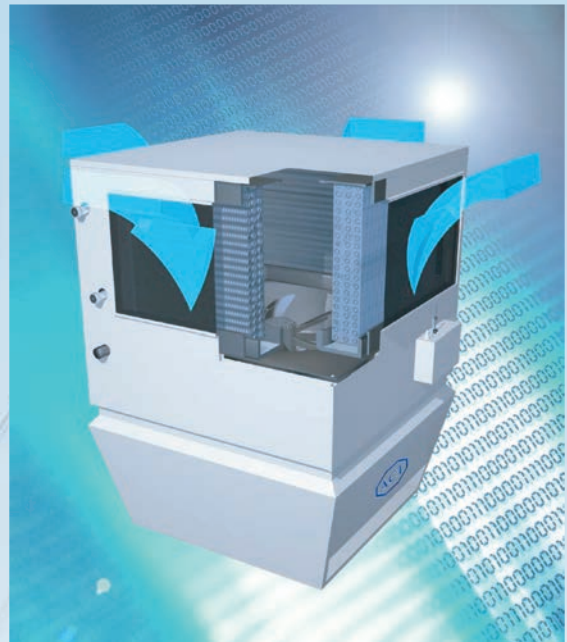
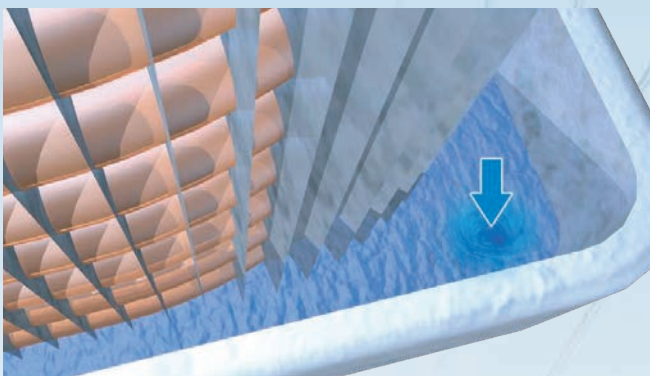

Fan Stop Status

In the event that the fan stops running, the cold water still passes the surface air cooler. Due to the lack of air drying, the aluminum foil fin of the surface air cooler has lower temperature and greater condensed water volume. Considering the effects of wind resistance, the condensed water flows down to the water catchers completely under gravity and is discharged from the condense pipe for ACT-K products in the absence of wind. The water catchers with the water capacity of 18 liters of ACT-K products are placed on four sides below the surface air cooler, far meeting the condensed water production and discharge rate under extreme humidity conditions.



Air Distance and Heating Affect

ACT-K products, with long air distance, high hot and cold air volume and installation height up to 20m, have no parts between the fan and the air outlet.

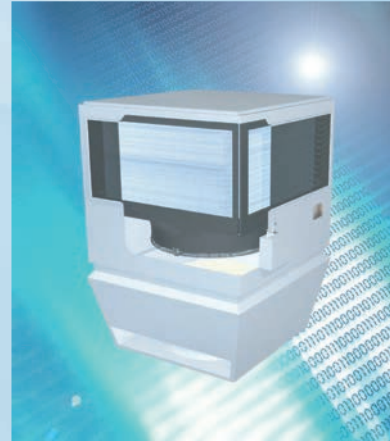

Noise and Installation

The fans of ACT-K products are installed inside the equipment to effectively reduce the noise. The shell inside the hot and cold unit equipment is attached with noise reduction and sound absorption materials to further noise. ACT-K products, with all-round return air reduce the structure, can be attached to the top and requires less installation space.



Mouth-shaped Surface Air Cooler

With latticed and complexly manufactured surface air cooler, the heat exchange area of 1.5 times of general surface air cooler, more significant heating and cooling effect, small wind resistance, large hot and cold air volume and large heat exchange area of surface air cooler.

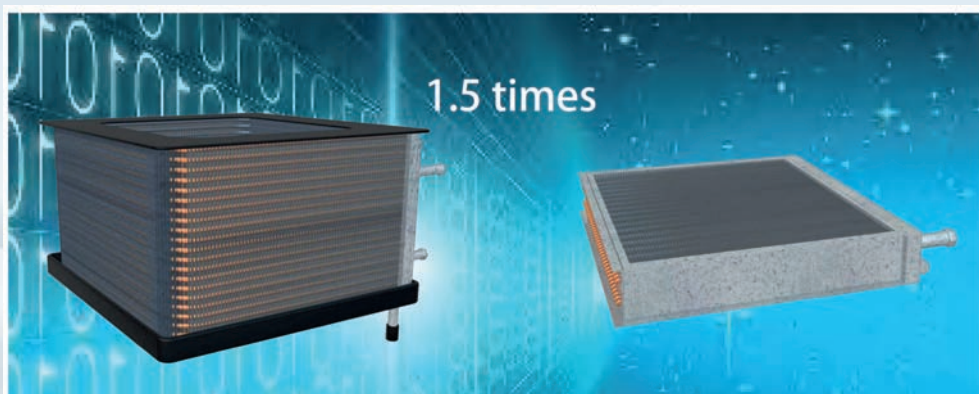



ADVANCE COOL TECHNOLOGY CO.,LTD.



Outdoor Unit



Outdoor Module Frequency Unit ACT-IX series

Applications: ideal for high and large space that needs cooling and heating.

Combine the direct-expansion and multi-connected unit with the recirculated air heating and cooling unit and other indoor units and use R410A as the medium.

Model: ACT-IX series

Function: cooling, heating

Cold and hot source: R410A

Control mode: wireless control, variable frequency, auto monitoring

Working Principle

◆ The VRF air conditioners, also known as "one-to-many," is a type of system where one outdoor unit is connected to several indoor units. Each indoor unit can operate independently or be controlled together. The system has an outdoor unit connected by pipes to indoor units that have components like outdoor heat exchangers, compressors, and other parts. The indoor units consist of fans and direct cooling elements. Using the pipes, the outdoor unit can supply cooling liquid to many indoor units. It controls the compressor's cooling fluid circulation and the flow into various indoor heat exchangers to meet the indoor cooling and heating needs.

◆ The system's working principle is simple: the indoor temperature sensor controls the valve on the indoor unit's cooling pipe. By adjusting the pressure, the system can control the outdoor unit's compressor speed or change its operating mode to adjust the cooling capacity according to the load.





Working Principle

The multi-unit system has some key features:



- ◆ **Significant energy savings:** The system adjusts the compressor speed and refrigerant flow automatically to operate more efficiently, reducing energy consumption during lighter use and lowering overall costs.
- ◆ **Space-saving design:** The outdoor units, usually installed on the roof, take up no extra space. With just refrigerant and water pipes.
- ◆ **Easy installation and reliable operation:** The multi-unit system has a simple setup, making it suitable for homes. With fewer components, the system runs reliably and safely.

Functions

- | | |
|---|--------------------------------|
| ⚠ Fall prevention warning monitoring | 📶 Wireless intelligent control |
| ⚡ Energy saving, lower investment | 🌊 R410A as the medium |
| 📊 Working data collection and analysis | 🌟 Filter net self-cleaning |
| 🏠 Support full ACT products linkage control | 🌀 Light breeze air supply |

Specification



Outdoor Module Frequency			ACT-250AX	ACT-280AX	ACT-335AX	ACT-400AX	ACT-450AX	ACT-500AX	ACT-560AX	ACT-615AX	ACT-670AX	ACT-730AX	ACT-785AX	ACT-850AX	ACT-900AX	
Power		HP	8	10	12	14	16	18	20	22	24	26	28	30	32	
Power supply	Three-phase and five-wire system 380V3N 5%~50HZ															
*1 Rated refrigerating capacity		kW	25.2	28.5	33.5	40	45	50.4	56	61.5	68.5	73.5	78.5	85	90	
*2 Rated heating capacity		kW	27	31.5	37.5	45	50	56	63	69	75	81.5	87.5	95	100	
Rated power consumption	Cooling	kW	5.45	6.75	8.4	10.25	12.1	13.5	16	17.87	18.6	19.27	20.95	22.85	24.65	
	Heating	kW	5.41	6.6	8.3	10.28	12.15	13.6	15.6	17.3	17.6	19.01	20.55	23.05	24.15	
Machine size	L×W×H	mm	930x860x1690			1240x860x1690			1500x860x1690			1900x860x1690				
APF			5.3	5	4.9	4.9	4.8	4.7	4.7	4.7	4.5	4.6	4.6	4.55	4.5	
Standard circulating airflow		m ³ /h	12000			13980			25800			27000				
*3 Operating sound		dB	56	56	57	59	60	61	62	62	62	62	63	64	64	
On-site piping size	Liquid pipe	mm	φ9.52	φ9.52	φ12.70	φ12.70			φ15.88			φ19.05				
	Air pipe	mm	φ22.23	φ22.23	φ25.40	φ28.58			φ28.58			φ31.75				
Weight		kg	220	225	230	285	290	290	345	370	375	450	455	460	465	
Refrigerant	Name	R410A														
	Self-contained filling capacity	kg	8	8	8	10	10	10	14	14	14	16	20	20	21	
Running range	Cooling	°C DB	-5~56°C						-5~56°C							
	heating	°C WB	-5~56°C						-5~26°C							
*4 Maximum fuse wire current	MFA	A	20	20	32	40	40	50	63	63	63	80	80	80	80	
*4 Minimum line current	MCA	A	17.6	21.7	28.4	35.2	40.2	48.1	51	54	55	66	68	70.1	72	

Note: Modules can be assembled, the maximum assembled total refrigerating capacity is 64HP.

- Nominal cooling capacity is determined according to the following conditions: Indoor temperature :27.0°C DB/19.0°C WB, outdoor temperature: 35.0°C DB, equivalent pipe length: 10m, difference of height: 0m;
- Nominal heating capacity is determined according to the following conditions: Indoor temperature: 20.0°C DB, outdoor temperature 7.0°C DB/6.0°C, equivalent pipe length 10m, difference of height: 0m;
- The noise level is tested before delivery. In the actual use, the measured noise may be different from the value specified in the table; in the quiet mode at night, noise is reduced by 5-8dB



HVLS FANS



HVLS FANS

(Permanent Magnetic Synchronous Motor)

The ACT HVLS fans adopt wing shaped blades, which can minimize air resistance and efficiently convert electrical energy into kinetic energy of the air.

It can stir the indoor air thoroughly and create a natural wind effect with adjustable wind speed, providing a comfortable indoor environment in high and large spaces.

Working Principle



Permanent Magnetic Synchronous Motor (Inner Rotor)

 *Large Airflow*

 *Low Noise*

 *Energy Saving*

 *Maintenance-free*



Working Principle

Stereoscopic Natural Wind

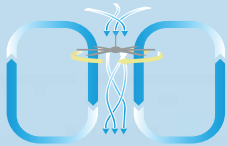

Circulating air supply in enclosed space, forming effective circulating airflow

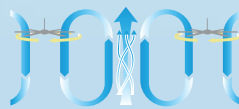

Circulating air supply by multi fans, effective upward airflow can be formed between fans



Full range and large area air supply, suitable for various large spaces

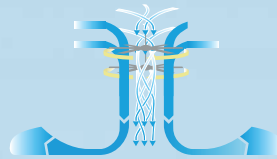

Low-speed uniform air supply, high volume, stable wind speed

Large Coverage Area

The ACT-F series large energy-saving fans adopt wing shaped blades, which can minimize air resistance and efficiently convert electrical energy into kinetic energy of the air. The airflow covers a range beyond the diameter of fan, pushing the airflow vertically towards the ground, forming a 1-3 meter high airflow layer on the ground, thus forming a super large coverage area not only limited to fans size.

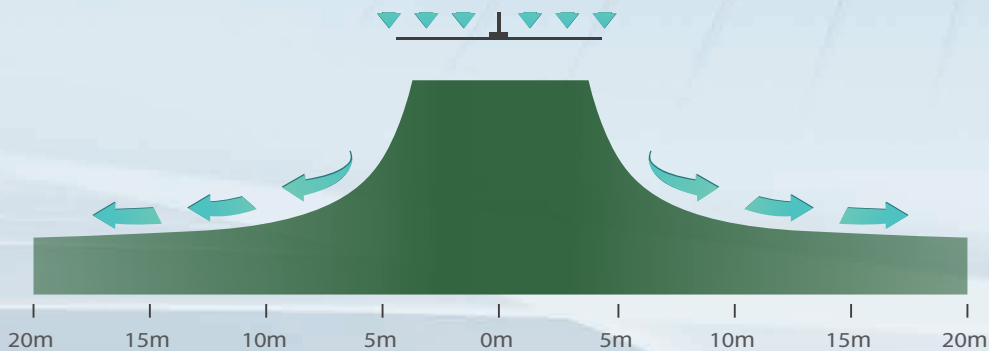

Design Suggestions

Our Suggestion--Layout Plan for Low Populated Areas

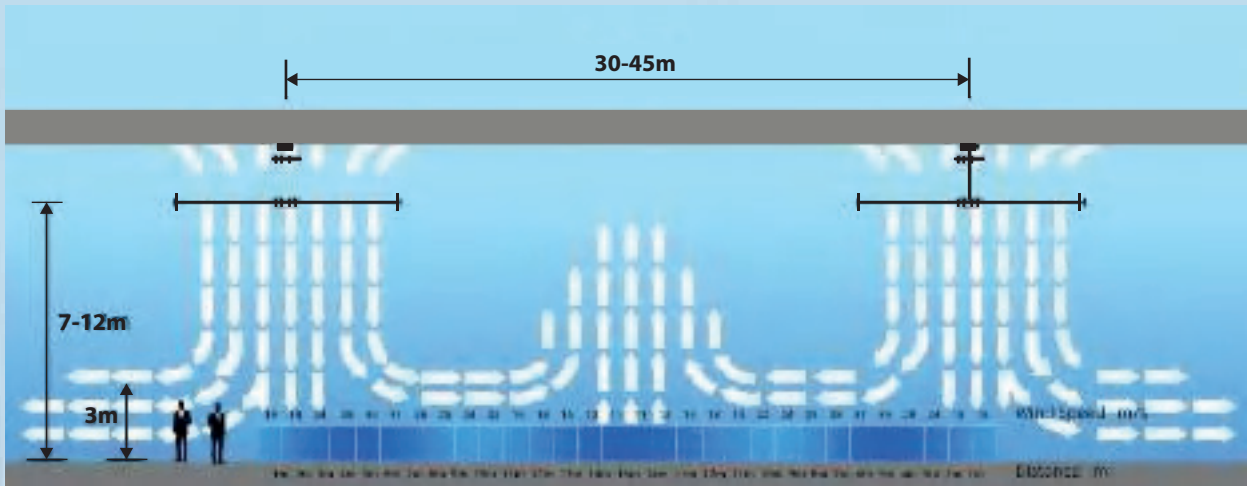

Remarks: Fan blade height from the ground: 7-12m Airflow layer height:3m Test height:1.5m

Our Suggestion--Layout Plan for High Populated Areas

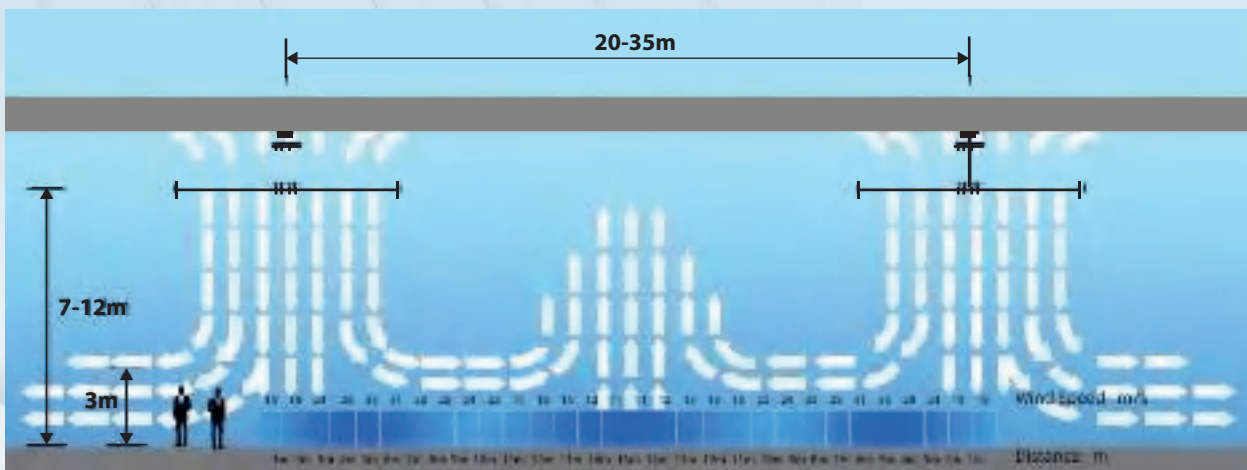

Remarks: Fan blade height from the ground: 7-12m Airflow layer height:3m Test height:1.5m



Technical Specifications

AirTS-F



Model	ACT-F49	ACT-F55	ACT-F61	ACT-F73
Blades (PCS)	5	5	5	5
Diameter (mm)	4900	5500	6100	7300
Rotation range (RPM)	15-75	15-65	15-65	15-55
Max airflow (m ³ /min)	10500	11500	12500	13000
Voltage (V)	110/220/380	110/220/380	110/220/380	110/220/380
Frequency (Hz)	50/60	50/60	50/60	50/60
Motor power (kW)	0.75	0.75	1.00	1.20
Rated current (A)	1.8	1.8	2.3	2.7
Noise (dB(A))	38	38	38	38
Coverage area (m ²)	500	600	1000	1700
Body weight (kg)	80	105	120	135

Weight: Control box, extension rod, top connector not included.

Standard Control



Cover outside

1. Electrical protection
2. Knob speed control
3. Digital display



Converter Inside

More Safety and Reliable

Electrical protection: It has protection functions, such as overvoltage, undervoltage, loss of voltage regulation, overload, collision, overheating, lightning strike, abnormality, and alarm linkage and so on.

Running indicator light (RUN): When the light is off, the inverter is in shutdown state; when the light is on, the inverter is in running state.

Keyboard operation, terminal operation and remote operation (communication control) indicator light (LOC):

- LOC light off: Panel start/stop control.
- LOC light on: Terminal start/stop control.
- ◐ LOC light blink: Communication start/stop control.

Tuning/Torque Control/Fault Indicator Light (TUNE):

When the light is on, it means it is in torque control mode. If it flashes slowly, it is in tuning state. If it flashes quickly, it is in fault state.



Optional IoT Control

IoT control by mobile APP for Android:

1. Remotely monitor the operating status of HVLS Fans
2. Data collection, analysis in time
3. Error alarm when fault happen
4. Support group control about 200 units

Operation View:

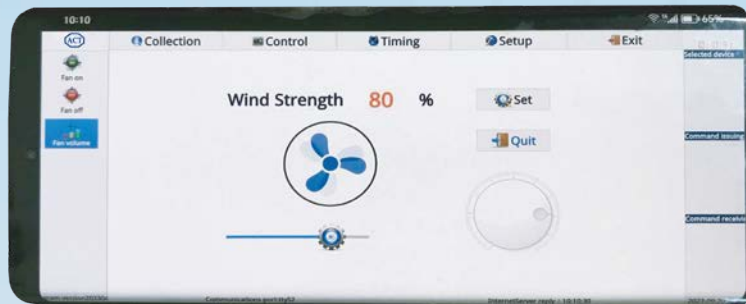

Optional Wireless Control System

1. Wireless control operation
2. The host computer can monitor all devices within a radius of 1km
3. Centralized control of multiple devices, partial control, single machine single control
4. Support for remote control by mobile APP
5. Accurate energy-saving and consumption reduction, automatic operation
6. Data recorded, multi-dimensional analysis
7. Support full ACT products linkage control

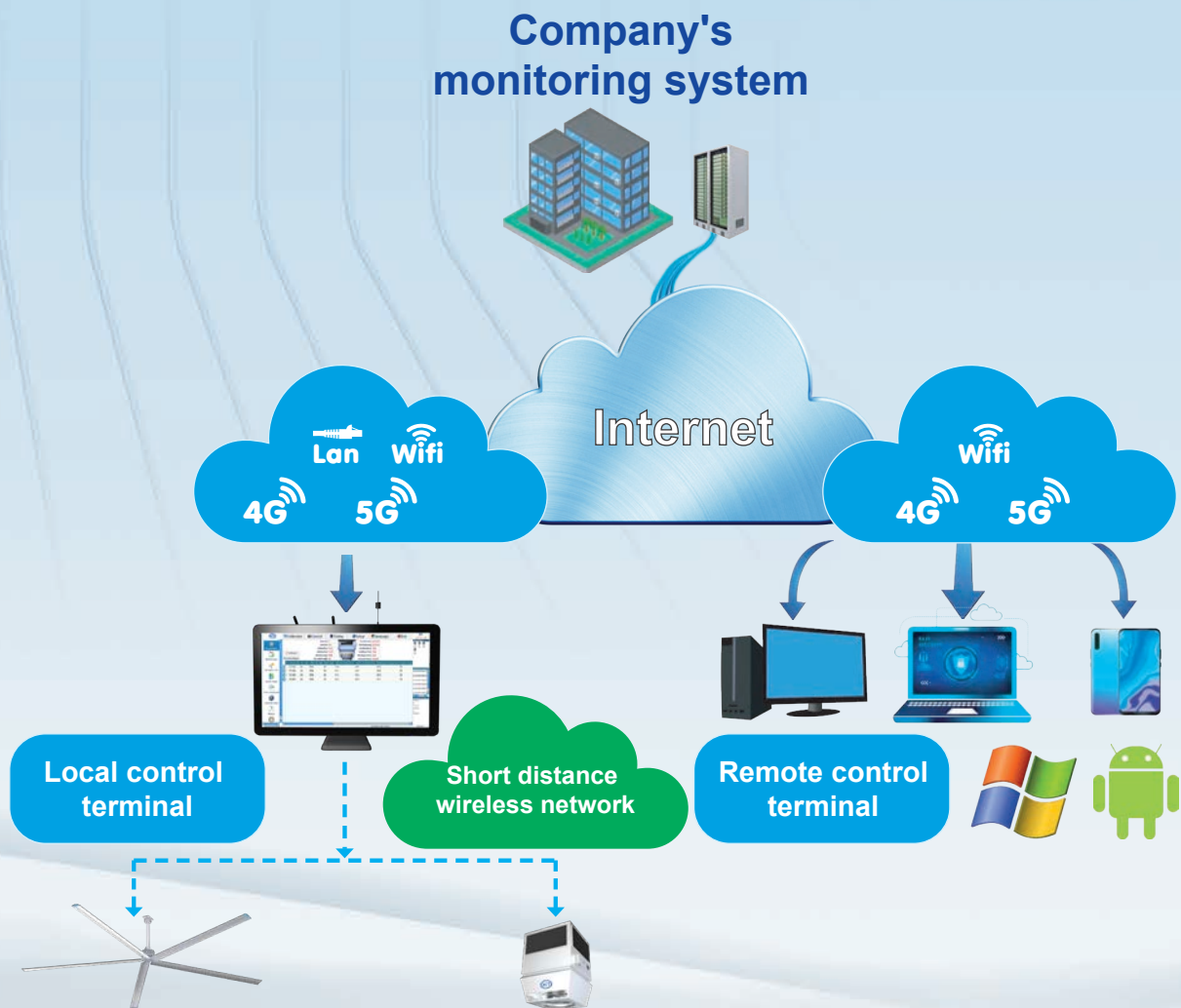

Advantages

New Permanent Magnetic Synchronous Motor (Inner rotor)

1. Lifetime increased more than 20%
2. Protection grade IP65
3. 180°C temperature resistant permanent magnet
4. Primary energy efficiency
5. Weight reduced 20%
6. High quality imported brand bearing



PMSM VS Gear Shifting Motor

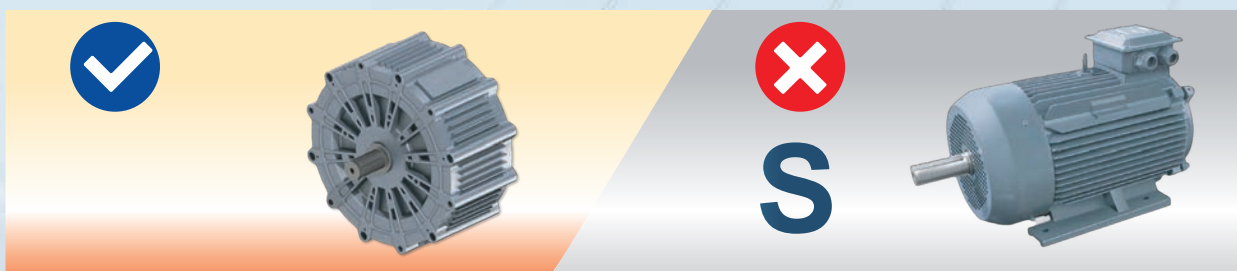

PMSM Motor Advantages:

- A** More energy saving
- B** Simple structure
- C** Smaller size and lighter weight
- D** Low noise
- E** Frequency range: 0-50Hz
- F** Direct drive motor without a maintenance

Gear Shifting Motor Weakness:

- A** More power consumption
- B** Complex structure
- C** Bigger size and heavier weight
- D** Loud noise
- E** Frequency range: 25-50Hz
- F** Gear shifting motor, the gear should be replaced

ACT-F Inner VS Outer Rotor



Inner rotor structure advantages:

- A Better heat dissipation :** Stator is outside (heat source).
- B More safety:** The rotating parts are only the motor shaft and fan blades.
- C Longer lifetime:** The hanger rod and motor can be integrated as a whole, and the rotating bearings only need to bear the weight of the wind blades, slightly wear.
- D Stable operation:** The motor body and fixed steel wire rope are fixed on the motor mounting plate, and the motor does not rotate.

Outer rotor structure weakness:

- A No better heat dissipation:** Stator is inside (heat source).
- B Less safety:** The rotating parts include the motor body and fan blades.
- C Shorter lifetime:** Single hanger rod, small stress area, and heavy bearing capacity.
- D Easy to shake:** The hanger rod bears all the weight of the fan and the torque generated during operation.



Installation

Installation Requirements

1. Input power: 110-120V, 380-460V (3 phase) or 220-240V (can meet special power supply requirement)
2. Building total height: $\geq 3.5\text{m}$
3. Building structure: H-beam, I-beam, steel-concrete, square beam, etc.
4. Safety distance : The minimum safety distance between the fan blades and obstacles is 0.2m.

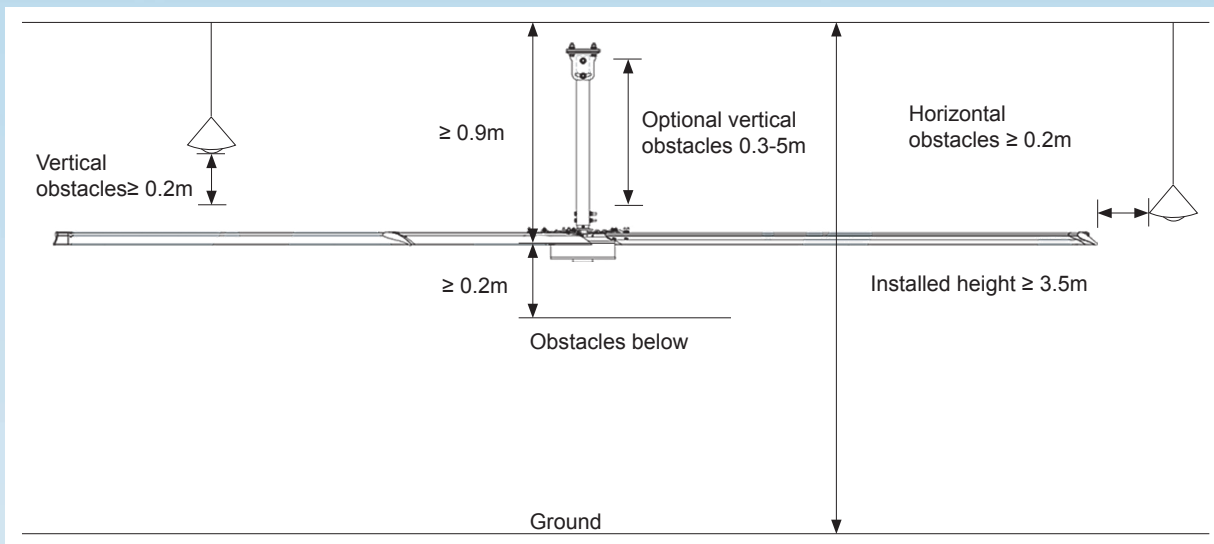

1. The maximum torque generated by fan is 300n/m, and the noise is $< 40\text{ dB(A)}$.
2. Places with continuous heat sources or oil fumes are not suitable for installation.
3. The distance between the control box and the fan should be less than 20m.
4. The roof should can be loaded over 150kg capacity, the total weight of fan equipment is about 120kg.
5. The spacing between adjacent fans is 30m.
6. The optimal installation height of the fan is about 7-9m between fan blade and ground, the minimum is no less than 3.5m.
7. The net height of building should be above 4.2m, and the distance of load bearing columns should be greater than the diameter of fan, above 60cm.

Control System



ACT-VM Air-conditioning Control System

Wireless control operation

Remote maintenance service

Intelligent frequency conversion control

Comfortable air supply

Control of variable air volume and water volume

Self-cleaning and automatic replacement of filter net

Equipment state and data analysis

Single machine control, zone control

Anti-falling warning and monitoring

Anti-freezing protection

System linkage control



Working Principle

Some System Functions

The condensed water in the cooling conditions is the core technical problem bothering the air conditioning technicians. ACT-K products conduct technical processing in the following two aspects, completely solving the stratigraphic leak of condensed water.



Collection

- All parameters
- Wind intensity
- Temperature and humidity in working area
- Output power
- Check the frequency modulator
- Equipment balance

Control

- ON/OFF
- Air outlet angle setting
- Wind intensity setting
- Water flow adjustment
- Backblowing and dust removal function

Timing

- Switch time setting
- Holiday function setting
- Automatic temperature control setting
- Regional temperature setting
- Automatic dust removal setting

Setting

- Wind speed limit setting
- Cold and hot season setting
- Anti-freezing protection setting
- Control mode

Functions

- ◆ Timer ON/OFF
- ◆ Centralized display and control
- ◆ Worry-free hosting function
- ◆ Fall prevention warning monitoring
- ◆ Wireless control
- ◆ Mobile app monitoring
- ◆ Filter net self cleaning
- ◆ Single machine control, zone control
- ◆ Wireless control
- ◆ Remote maintenance
- ◆ Auto protection
- ◆ Air velocity and intensity control
- ◆ Auto temp control
- ◆ System linkage control
- ◆ Supply air wind free
- ◆ Intelligent inverter control
- ◆ Control of variable air and water volume
- ◆ Data collection and analysis
- ◆ Compatible with multi systems
- ◆ Energy saving



Specification

Industrial-grade touch screen computer, HMI setting, wireless control mode for all functions of equipment.

It has the remote control capacity, and multiple port extensions or upgrades.

1. Industrial grade wall-mounted computer with touch screen
2. Large screen easy to operate
3. 220V electrical connection, placed in any position
4. Centralized display, control of all devices
5. Small and exquisite, beautiful, small space usage
6. Convenient monitoring and control



Application

Company's monitoring system

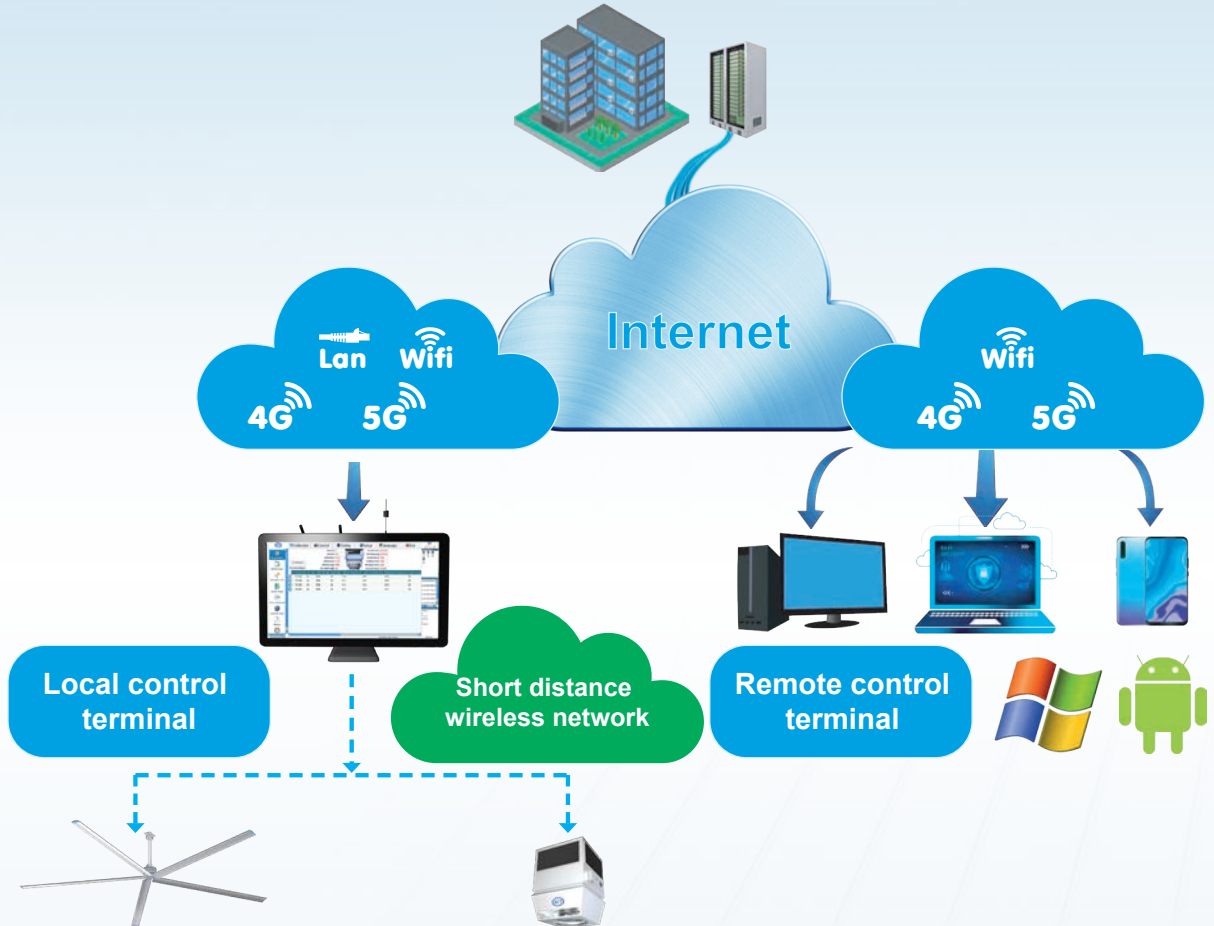



THE CHILLER EXPERT



www.advance-cool.com



Advance Cool Technology Co., Ltd



@advancecool



0-2187-0660